

next
kiosk

FreezeFire™ Kiosk

24/7 Frozen or Refrigerated to Speed Cook

Powered by
Kiosk
OPERATORS

STANDARD PROPERTIES

- **Overall Dimensions:**
5.92 ft W x 4.58 ft D x 6.25 ft H
- **Meal Capacity:** 65 – 104
- **Storage Temperature Range:**
-4°F to 5°F (Freezer)
- **Heating Method:**
TurboChef Rapid Cook Oven (5,200–6,400W)
- **Cooking Time:**
Hot meals ready in under 4 minutes
- **Outer Material:** Reinforced Steel
- **Inner Material:** 304 Stainless Steel (food-grade)
- **Thermal Insulation:**
75 mm dual-zone polyurethane insulation
- **Interior Coating:**
IFS anti-microbial powder
- **Pickup & Delivery System:**
Smart robotic functionality
- **Lighting:**
LED lit interior and pickup indicator
- **Security:**
Enterprise-grade firewall/router + optional cameras
- **Remote Access:**
Cloud-based control & diagnostics



Indoor Placement Recommended

CUSTOMIZABLE FEATURES INCLUDED



Custom Colors
All RAL colors available



User Experience
Branded graphics and video content

OPTIONAL UPGRADE FEATURES



Your Brand
Custom wrap design



Security
Security cameras for real time monitoring & reporting

**1 YEAR
WARRANTY**



Hot Food Kiosk

Technical Specifications



5.91 ft W x 4.58 ft D x 6.25 ft H

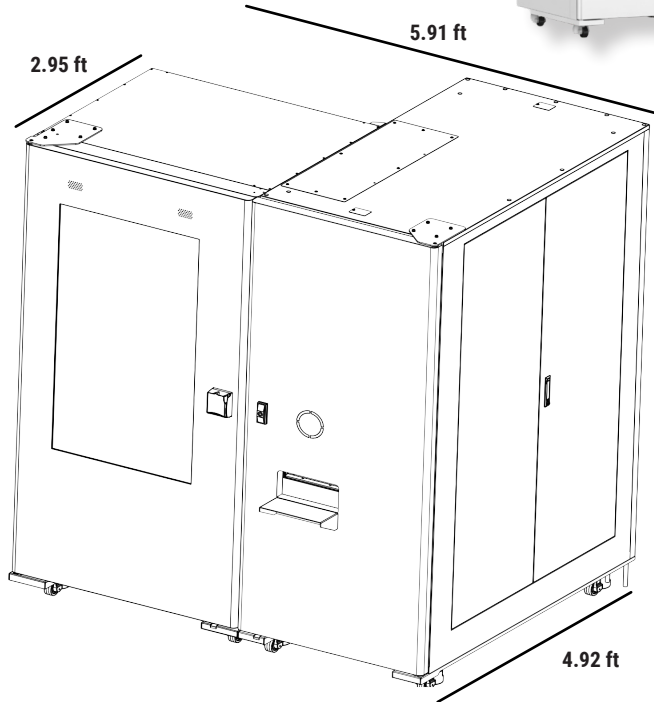

OPERATING

Internet	5G/WiFi/Ethernet
Scanner	2D QR/Barcode
Software	Cloud-based Management Platform
Sensors	Temperature, Machine Health, Oven Status

- Open API integration
- Interactive User Interface
- Secure, integrated payment system
- Remote management portal
- Inventory management system
- Detailed customized reports

HARDWARE

Model Number	FK-092-WF-HO (Frozen-Heated Option)
Touchscreen	48" 4K Interactive Display
Payment system	Apple Pay, Google Pay, Credit/Debit, Uni POS
Temperature Zones	-4°F to 5°F (Storage), 300°F-500°F (Oven)
Electrical	240V AC / 50A / Single Phase
Plug Type	NEMA 6-50P (Straight Blade)
Oven Partner	TurboChef (Rapid Cook, High Efficiency)



Simple Installation

No plumbing or external ventilation required.



Environmentally Friendly

We use R290, a refrigerant with low environmental impact and not harmful to Earth's ozone layer.



Non Condensing

Next Kiosks have a relative humidity of 10% - 95%, ensuring a dry, non-condensing refrigerated locker unit with zero sweat.



Food Grade

Next Kiosks are treated with anti-microbial coating for food safety, environmental protection, erosion resistance, and durability.

WWW.KIOSKOPERATORS.COM

469-505-0663

SALES@NEXTKIOSKS.COM



On Demand Dining Redefined

- Any meal, both hot and chilled menu items, 24/7
- Simple and fast customer experience
- Automation & operational efficiency
- Reduce labor & costs
- Revenue & business growth opportunity